

NOTE:

1. SUPPORT PIPING SO THAT THERE IS NO WEIGHT ON PUMP.
2. PROVIDE INERTIA BASE WHEN REQUIRED BY SPECIFICATION, OTHER DETAILS OR SCHEDULES.

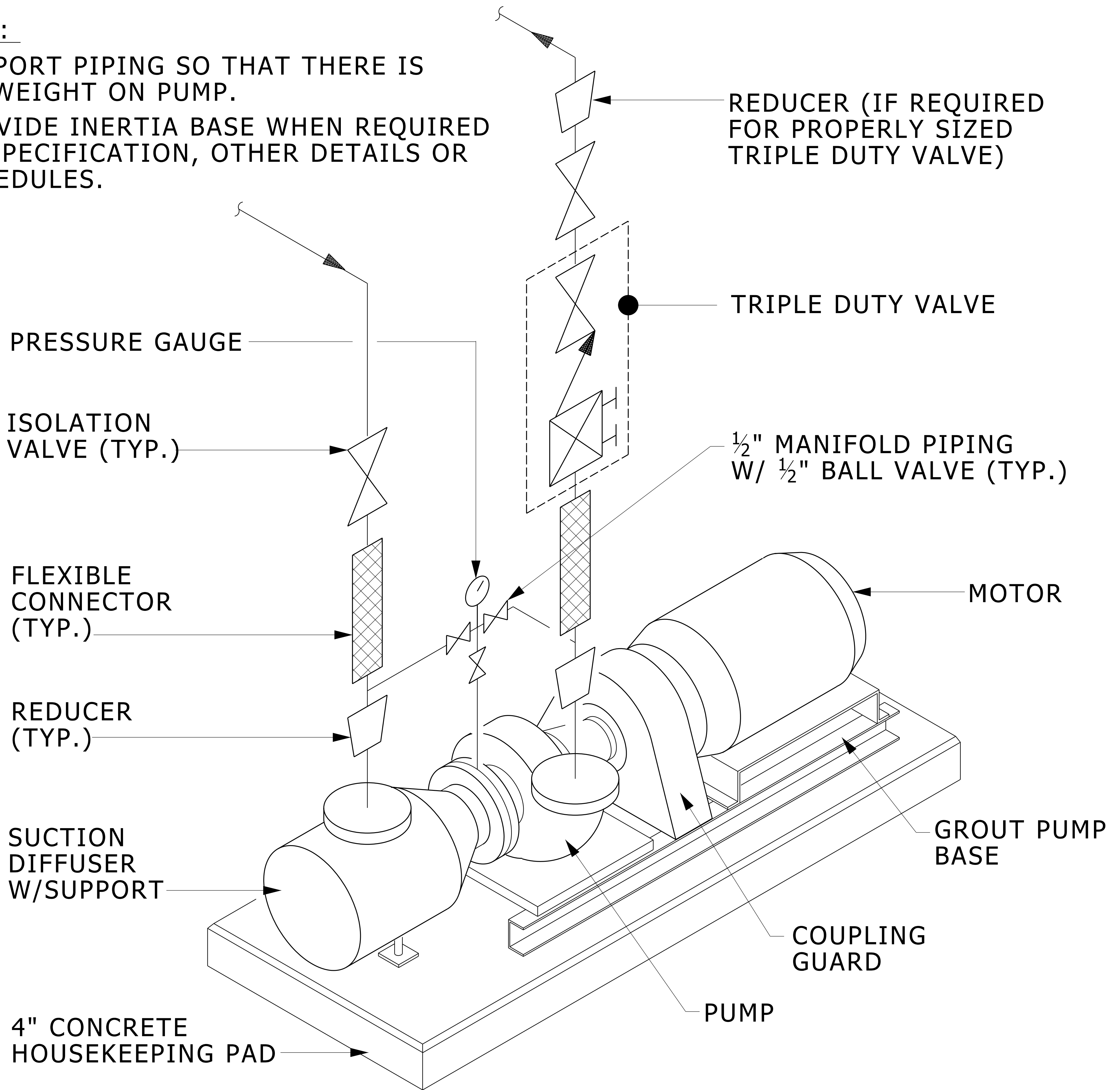

END SUCTION PUMP INSTALLATION

NO SCALE

MD 232123 001 2012-11-01

DESIGNER NOTES: FOR VARIABLE VOLUME SYSTEMS, DELETE TRIPLE DUTY VALVE AND SHOW A CHECK VALVE INSTEAD.